

PUREZZA™

PREMIUM WATER





CONTENTS

The Purezza Difference	p4-5
Our Quality and Safety Assurance	p6
Superior Filtration Technology	p7
Our Service Promise	p8
Countertop Systems	p9
Underbench Systems	p10
Dispensers	p11-15
Speciality Products Designed for Hotels	p16
Accessories and Package Add-ons	p17-18
Marketing Bundle	p19
What our Customers say	p20
Connect with us on Socials	p21
Our Customers	p22-23



THE PUREZZA DIFFERENCE

Purezza is an end-to-end sparkling and still water solution, offered exclusively to the hospitality channel. Proudly served in over 65 countries, the Purezza experience combines global expertise with a local touch.



HIGHEST CAPACITY MACHINES IN THE MARKET

All our equipment is accredited by plumbing Australia. Our systems satisfy the need for dispensing high volumes of water, are food safe and produce the least specified rating of energy output.



SYSTEMS DESIGNED FOR THE AUSTRALIAN CLIMATE

Our Ice Bath cooling technology ensures still and sparkling water outputs are consistently maintained at ice-cold temperatures.

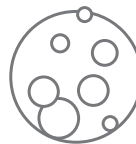

SUPERIOR CARBONATION

Our sparkling system includes CO2 gas pressure control and is engineered to deliver supreme quality ice-cold effervescent water, comparable to even the finest bottled water.



Join our mission to remove 30 million single use bottles from the hospitality supply chain annually.

PUREZZA BENEFITS



BEST FILTRATION

At Purezza, the quality and taste of our water is important. Our systems use the latest in filtration technology, with equipment designed specifically for high-flow beverage applications.



LARGEST SERVICE NETWORK

We employ 110 full time technicians across Australia meaning all service & maintenance is conducted by company people.



HIGHLY ACCREDITED AND CERTIFIED

Delivering safe and hygienic water solutions to our customers is of the utmost importance for Purezza. We are certified and accredited by well respected and world-renowned organisations.



UNLIMITED FRESH SPARKLING WATER

What makes our water premium? In one word: freshness. Using the latest technology, Purezza systems filter, chill and carbonate water at the point of dispense. This ensures that every time you pour Purezza water, it's of the freshest and highest quality.



REDUCE YOUR CARBON FOOTPRINT

Approximately 80% of plastic water bottles end up in landfills and then take up to 1,000 years to decompose. Purezza eliminates the need for single-use plastic bottles and demonstrates your commitment to environmental sustainability.



INCREASE OPERATIONAL EFFICIENCY

Say goodbye to the admin of managing inventory and the labour of stocking bottles. You can reclaim storage and fridge space while staff can stay hydrated without consuming retail stock.



EXPAND YOUR BEVERAGE MENU

Introduce indulgent new beverages that are simple to produce with Purezza. Just add syrups and natural ingredients to create home-made sodas, sparkling iced teas, mocktails and fruit detox waters. Ask about our Soda Boss recipe book, full of soda recipes for the modern-day mixologist.



BOTTLE YOUR PROFIT

Purezza represents a high-profit margin opportunity with a 750ml bottle costing an average of 6c to fill. Enjoy unlimited sparkling and still water for a low weekly cost. Add thousands to your bottom line every year!



CONTROL YOUR RETURN

You can choose to charge per bottle, list a cover charge for unlimited sparkling water or introduce function packages as a simple way to generate revenue.

THE HIGHEST STANDARD

Our underbench units and fonts are certified for delivering safe drinking water for businesses that operate a HACCP based Food Safety Program.

WHY IS HACCP IMPORTANT?

Food contamination is a major health problem in Australia with the estimated number of food poisoning occurrences exceeding two million per annum.

A thorough approach to food safety must be rigorously enforced in order to maintain measurable standards of cleanliness, food handling and storage.

If you're not using a HACCP certified system in your venue, how are you minimising risk to your customers?

WHY IS WORKING WITH A LICENSED PLUMBING COMPANY IMPORTANT?

For your peace of mind and to ensure your business receives the best care, it's important to work with a licensed plumbing company for all installation and service work.

Purezza/Waterlogic is a licensed & insured plumbing company that adheres to all Australian plumbing regulations, safety standards and guidelines.

OUR SAFETY & QUALITY ASSURANCE

PUREZZA IS PROUDLY TESTED & CERTIFIED BY:

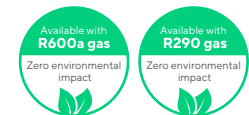

Green Key

Purezza has partnered with leading international eco-label Green Key with the aim of promoting sustainable water supply chains in the hospitality industry using filtered tap water solutions and reducing the use of single-use plastic bottles.

To find out more about the Green Key program, visit www.greenkey.global

SUPERIOR FILTRATION TECHNOLOGY

UVC LED PURIFICATION

UVC LED purification inactivates water-borne microorganisms.

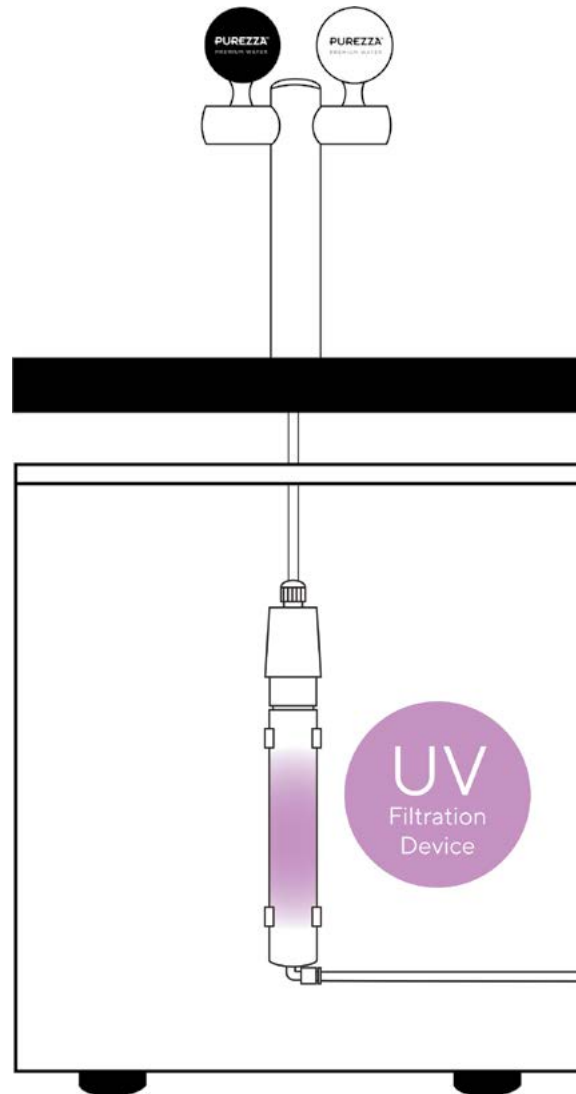

THE BEST QUALITY FILTRATION

At Purezza, the quality and taste of our water is important. Our systems use the latest in filtration technology, with equipment designed specifically for high-flow beverage applications.

- Fibredyne II media submicron technology reduces dirt and particles as small as 0.5 micron in size, and reduces pathogens such as Cryptosporidium and Giardia cysts
- AgION® antimicrobial protection inhibits bacterial growth on the surface area
- Premium filters ensure taste/ odour reduction and scale control, while retaining beneficial minerals



*illustration purposes only. UVC may vary depending on the dispensing system.



OUR SERVICE PROMISE

We don't see ourselves as just another supplier. Purezza is a partner who enables you to focus on your own business priorities by providing you with a seamless experience from the moment you pick up this brochure.

We are proud of our world-class customer service and strive to place your satisfaction at the core of everything we do.

In fact we are so confident in the reliability of our equipment and expertise of our team, in the unlikely event of a system failure we will refund double your rental for any period outside our 2 working day response time.

**conditions apply, visit purezza.com.au for more info.*

Your Purezza service plan includes:

- Direct access to our service team through 1300 792 673
- Dedicated Account Manager
- Troubleshooting handbook
- “Twice your daily rental refunded” promise if we don't resolve your issue in 2 working days.
- Scheduled routine maintenance
- Scheduled routine filter changes using sparkling water specialised & unique Purezza filters
- Unlimited no cost service call for any system failure
- Our “famous for our service” promise

'Lotus Dining Group has been using Purezza for almost 8 years and the service we get is always above and beyond.'

M. Morales Lotus Dining Group NSW

COUNTERTOP SYSTEMS



FRIZZANTE 80



CLASSE SYSTEM

CAPACITY PER HOUR	80L	CAPACITY PER HOUR	150L
IDEAL FOR	Conference space	IDEAL FOR	Hotels
DISPENSER OPTIONS	Mechanical taps	DISPENSER OPTIONS	Push buttons
UNIT DIMENSIONS	345 mm (W) 592 mm (D) 580 mm (H)	UNIT DIMENSIONS	400 mm (W) 590 mm (D) 573 mm (H)

Superior Purification Technology

WHAT IS FIREWALL® ?



Firewall® is the most highly certified UV technology in the world, purifying water at the point of dispense as it flows through the coil to the dispensing nozzle.

Thanks to our proprietary Firewall® technology, Classe is the first and only solution in the hospitality sector capable of delivering up to 99.9999% purified still and sparkling water.

BioCote® antimicrobial protection

BioCote® has built-in antimicrobial protection that reduces the presence of microbes, including bacteria and mould on surface areas and touchpoints, reducing the potential for cross-contamination

UNDERBENCH SYSTEMS



FRIZZANTE 100, 160 & 280

DELIVERY PER HOUR	100L	160L	280L
IDEAL FOR	Cafes	Restaurants/events	Hotels
DISPENSER OPTIONS	Selection of Cobra Head options Campione Tower Euro Tower	Selection of Cobra Head options Selection of T-Bar options Campione Tower Euro Tower Gemelli Tower	Selection of Cobra Head options Selection of T-Bar options Campione Tower Euro Tower Gemelli Tower
UNIT DIMENSIONS	340 mm (W) 513 mm (D) 517 mm (H)	506 mm (W) 474 mm (D) 608 mm (H)	791 mm (W) 579 mm (D) 812 mm (H)

*All systems compatible with the Murano Tower at an additional cost

DISPENSERS



CAMPIONE TRIPLE DISPENSER

MURANO TOWER

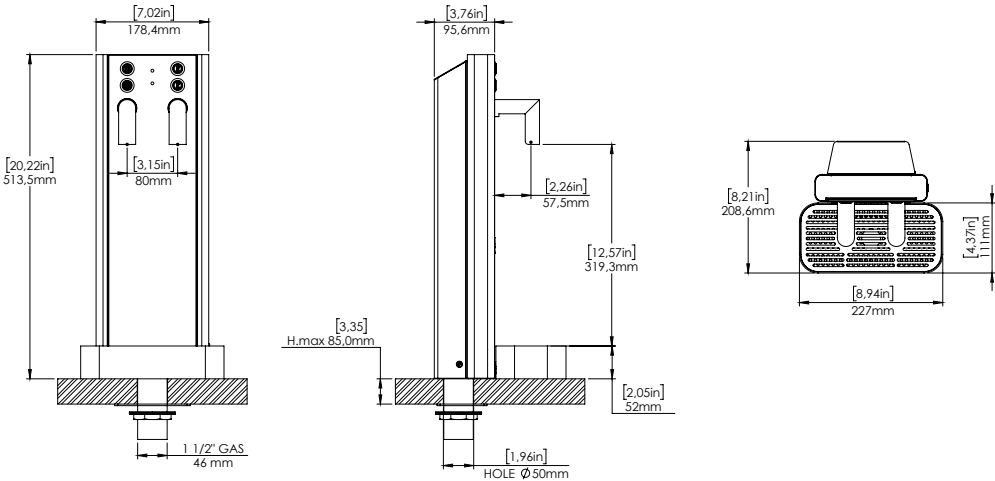
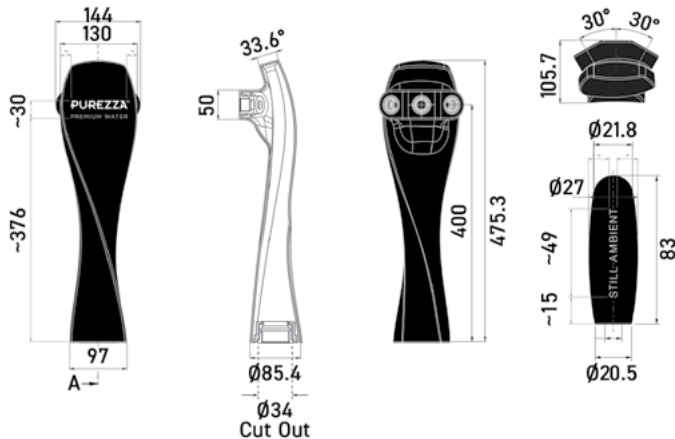



DISPENSERS



EURO TOWER



Antique Copper

GEMELLI TOWER

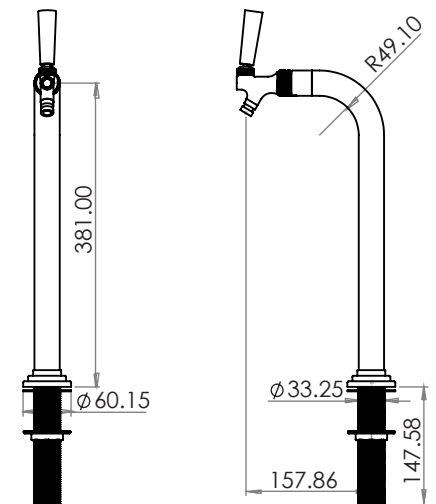
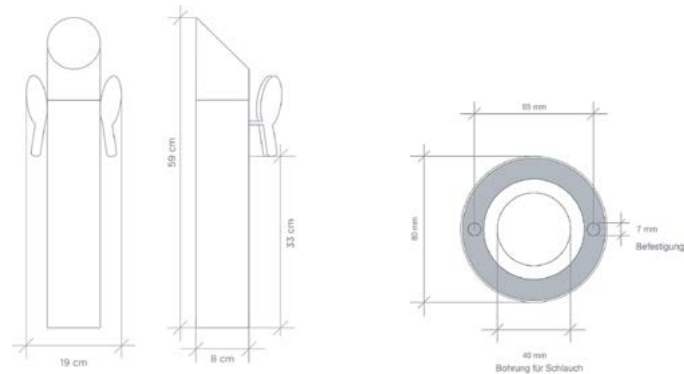

DISPENSERS



Matte Black



Brushed Stainless Steel



Matte Black



Pearl White



Copper

THREE-WAY T-BAR DISPENSERS

TWO-WAY T-BAR DISPENSERS

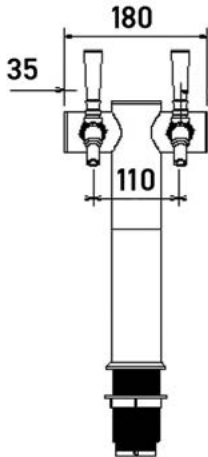
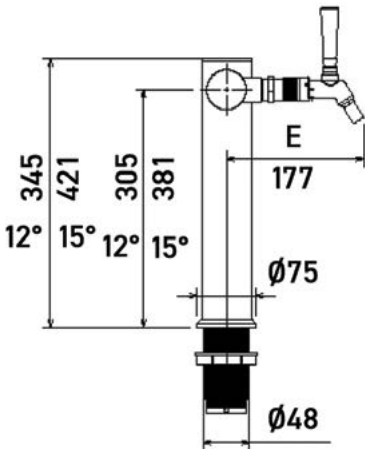
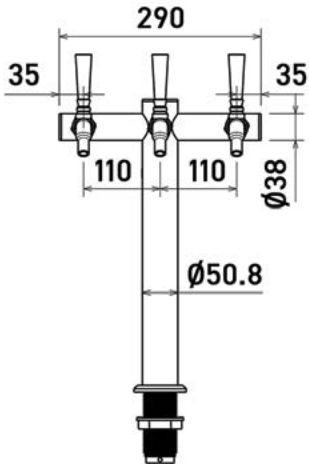
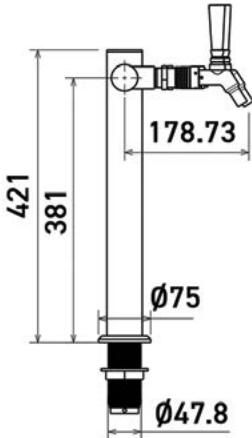

DISPENSERS



Single



Double



Triple

Available finishes



Matte Black



Brushed Brass



Gold

COBRA HEAD DISPENSERS

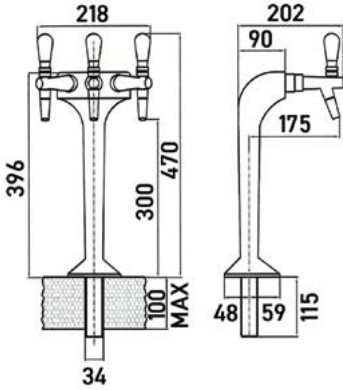
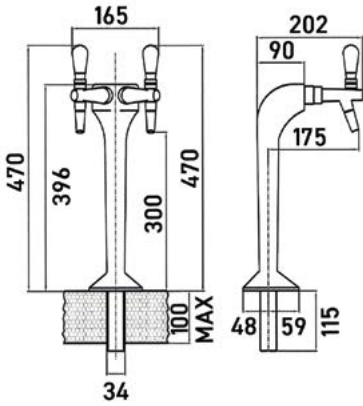
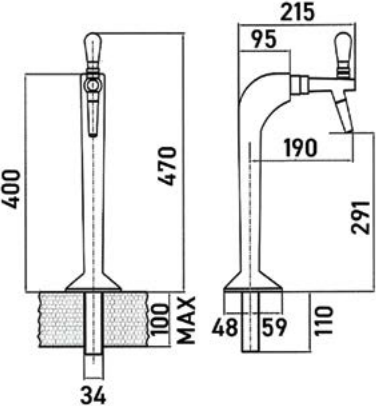

FILTER TAPS



Chrome



Matte Black



MINI COBRA HEAD DISPENSER

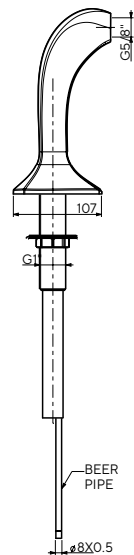
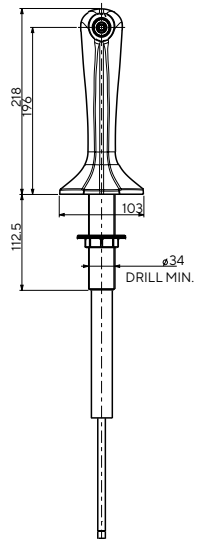

DUAL LEVERED GOOSENECK

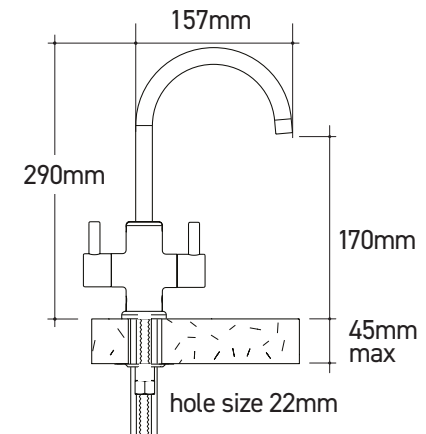



SPECIALITY PRODUCTS DESIGNED FOR HOTELS

The perfect sustainable in-room drinking water solution for hotels.



PURIFICATION	Firewall® UVC purification technology
WATER TYPE	Ambient
INSTALL TYPE	Plug & go
IDEAL FOR	In-room water solution
MAINTENANCE	Filter change annually
UNIT DIMENSIONS	139mm (W) x 349mm (D) x 306mm (H)
RESERVOIR CAPACITY	2L
GUARANTEE	12 months

ACCESSORIES AND PACKAGE ADD-ONS

NEW & EXCLUSIVE DESIGN

\$6.95 each for 350ml

\$7.95 each for 750ml



350ml & 750ml PUREZZA PETALOSA SERVING BOTTLES

Purezza Petalosa glass bottles add a touch of sophistication to any venue. Our reusable bottles remove the need for disposable plastic bottles, dramatically reducing your environmental impact. The bottles are delivered in boxes of 12 and are available in a still or sparkling design.

BOTTLE MOUTH DIAMETER
Wide mouth opening designed for dishwasher and glass washer cleaning

NECK-SHOULDER SHAPE
Angle-free shoulder maximises water in-flow during washing

BOTTLE HEIGHT
At under 28cm, the bottle has the added advantage of fitting in standard 30cm glass washers

GLASS WEIGHT
Thick glass, weighted base for greater strength and stability



CAPS
The screw-finish caps are reusable, dishwasher-safe and more hygienic than swivel caps and single-use pull-ring caps

BOTTLE FINISH
Smooth finish prevents internal particle build-up

TAPERING BASE
Tapered, ergonomic base for comfortable handling

\$7.95 each



600ml ALUMINIUM BOTTLES

The Purezza durable aluminium, re-usable bottles are a cost-effective, eco-friendly solution that encourage good hydration, keep drinks refreshingly cold and are leak free.

ACCESSORIES AND PACKAGE ADD-ONS

\$70.00
per box
(1000)



PAPER CUPS

Add on
for just
\$40 each



WOODEN HANDLES

Add on
for just
\$4.95/week



PLUMBED IN DRIP TRAY

Add on
for just
\$149 +GST



DISH WASHING RACK

Add on
for just
\$15/week



PZ KEG CUBE

Add on
for just
\$3.95/week



CLASSE BASE CABINET

Add on
for just
\$3.95/week



FRIZZANTE 80 BASE CABINET

MARKETING BUNDLE



WINDOW
STICKERS



POSTER



TENT
CARDS



WHAT OUR CUSTOMERS SAY

Chef
Alessandro
Pavoni

"I always tell people, 'Go with Purezza, go with a system like this.' It makes sense, it should make sense for everybody."

Chef
Giovanni
Pilu

"Purezza is conveniently easy to use, drives profit to the bottom line, adds versatility to the menu and reduces our carbon footprint. Best of all, the freshness tastes like home."

M.Richardson,
Rendezvous
Hotel,
Scarborough,
WA

"Perth being the most remote capital city in the world, we do source our produce locally, and one of those items is our water. Purezza is filtered at the point of dispense, it is excellent quality still and sparkling water which enables us to provide world-class water for our customers, which complements the world-class food that we provide in our restaurant."

A. France,
Bondi
Trattoria,
NSW

"We love serving water that doesn't involve unnecessary packaging! It keeps you beautiful and saves the planet."

C. Haggarty,
Cru Bar &
Eatery,
VIC

"Who doesn't love sparkling water! It's great to be able to offer it to guests unlimited per person. It also adds a special touch when served with black coffee as a palate cleanser."

CONNECT WITH US ON SOCIALS

    @purezzaaustralia



PROUD TO
SERVE IN
SOME OF
THE BEST
VENUES IN
AUSTRALIA



purezza.com.au

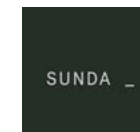

PUREZZA™

PREMIUM WATER

At Purezza Premium Water we are passionate about providing high-quality sustainable water dispensing solutions that deliver purified, great-tasting water.

The latest filtration technologies and first-class service ensures that you can enjoy unparalleled product quality and premium support you can rely on.

Contact us today to find out which Purezza solution is right for you.

1300 792 673 | purezza.com.au | sales@purezza.com.au